

BULK FLUID DISPENSING PACKAGES

Complete bulk fluid dispensing packages with 140, 230 and 330 Gallon CUBET tanks. CUBET tanks are ULC listed and they are made from HD-8760 high density copolymer that offers the following advantages:

- Environmentally superior.
- Long term UV stabilization.
- 250 mil wall thickness.
- Level always visible, no gauge needed.
- No vent cap needed.
- Will not leak or rust, seamless construction.
- Space saving, conserves floor space.
- Three 2" bung openings.

CUBETS can accommodate oil, water based fluids and other chemicals. They are also available with a dual containment steel basket that holds 110% of the tank volume.



C 142.14

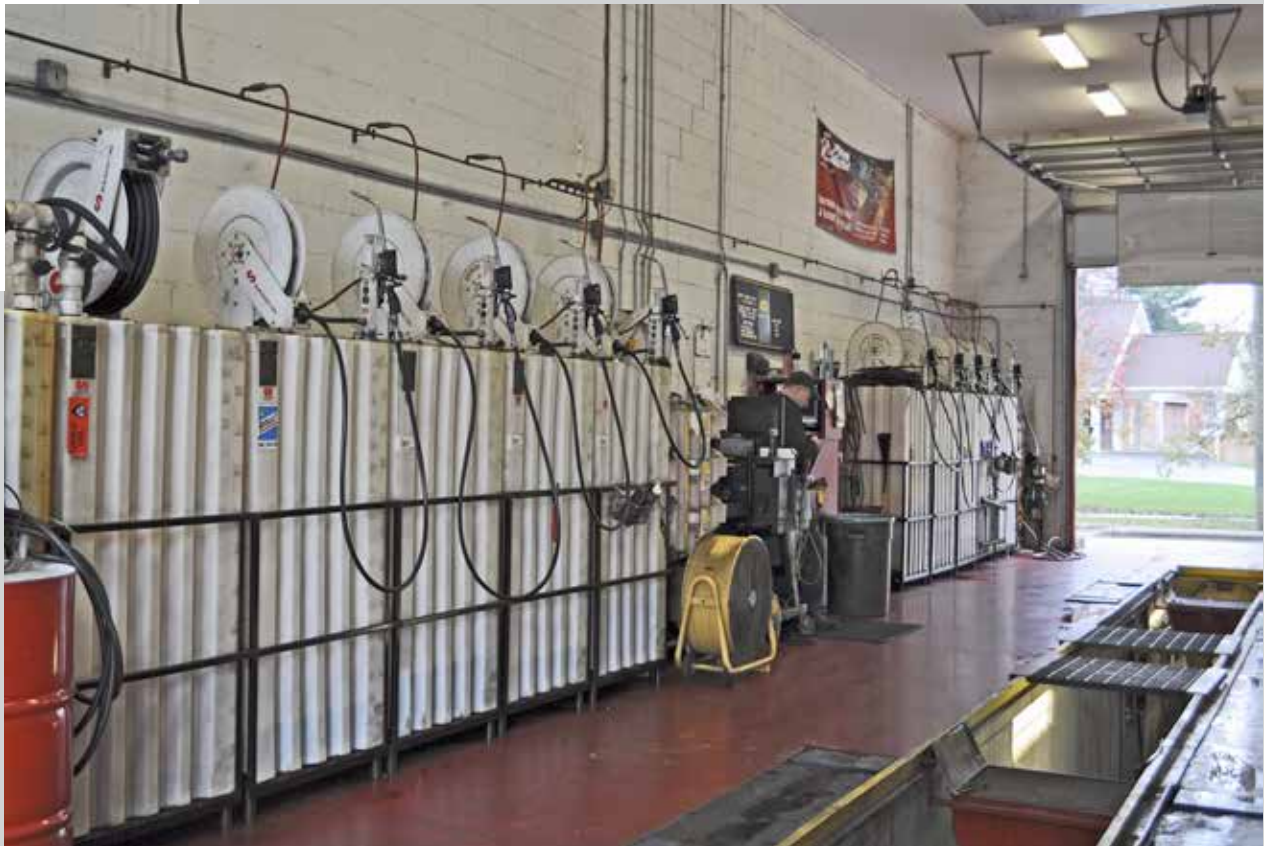

140 GAL PACKAGES

Dimensions

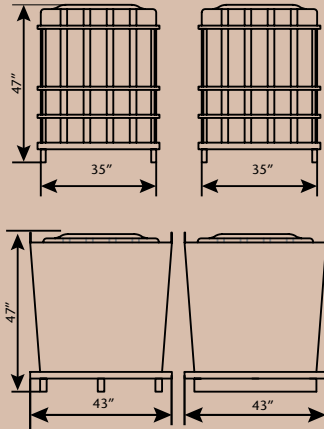

Tanks contain three 2" bung openings



06
BULK PACKAGES

PART No.	DISPENSE HOSE	DISPENSE HANDLE	TANK TYPE	FLUIDS
BARE TANKS				
3140	140 gal tank - tank and cage only		Cage	ALL
3140DC	140 gal tank - tank and dc only		Dual containment	ALL
PACKAGES FOR OIL WITH PM2 3:1 PUMP				
3214	10' Hose 847	Metered handle 365 536	Cage	OILS
3214DC			Dual containment	OILS
3216	30' x 1/2" hose reel 506 202		Cage	OILS
3216DC			Dual containment	OILS
3216P		Preset metered handle 365 817	Cage	OILS
3216DCP			Dual containment	OILS
PACKAGES FOR DEF WITH AIR-POWERED DIAPHRAGM PUMP 552 015				
550 004 140	30' x 1/2" hose reel 506 702	Automatic nozzle 688 303	Cage	DEF
PACKAGES FOR DEF WITH 110 V AC ELECTRIC DIAPHRAGM PUMP 560 215				
555 112 140	30' x 1/2" hose reel 506 702	Automatic nozzle 688 303	Cage	DEF
PACKAGES FOR WATER BASED FLUIDS WITH AIR-POWERED DIAPHRAGM PUMP 552 016				
3218	10' Hose 824 2	Dispense handle 186 300	Cage	WWF/AF
3218DC			Dual containment	WWF/AF

230 GAL PACKAGES



Dimensions

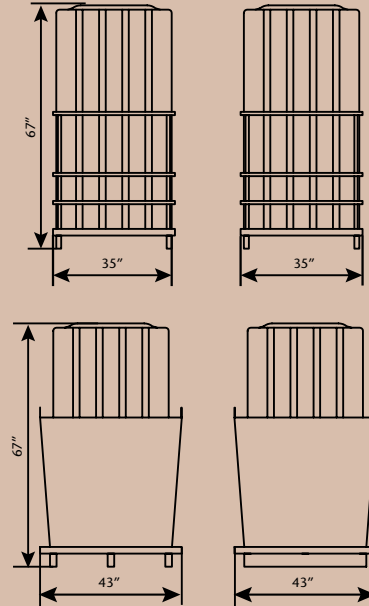

Tanks contain three 2" bung openings

06
BULK
PACKAGES

PART No.	DISPENSE HOSE	DISPENSE HANDLE	TANK TYPE	FLUIDS
BARE TANKS				
3223	230 gal tank - tank and cage only		Cage	ALL
3223DC	230 gal tank - tank and DC only		Dual containment	ALL
PACKAGES FOR OIL WITH PM2 3:1 PUMP				
3234	10' Hose 847	Metered handle 365 536	Cage	OILS
3234DC			Dual containment	OILS
3232	30' x 1/2" Hose reel 506 202		Cage	OILS
3232DC			Dual containment	OILS
3236	50' x 1/2" Hose reel 506 222	Preset metered handle 365 817	Cage	OILS
3236DC			Dual containment	OILS
3236P			Cage	OILS
3236DCP			Dual containment	OILS
PACKAGES FOR OIL WITH PM4 5:1 PUMP				
3238	50' x 1/2" Hose reel 506 222	Metered handle 365 536	Cage	OILS
3238DC			Dual containment	OILS
PACKAGES FOR DEF WITH AIR-POWERED DIAPHRAGM PUMP 552 164A				
550 004 230	30' x 1/2" Hose reel 506 702	Automatic nozzle 688 303	Cage	DEF
PACKAGES FOR DEF WITH 110 V AC ELECTRIC DIAPHRAGM PUMP 560 215				
555 112 230	30' x 1/2" Hose reel 506 702	Automatic nozzle 688 303	Cage	DEF
PACKAGES FOR WATER BASED FLUIDS WITH AIR-POWERED DIAPHRAGM PUMP 552 164				
3228R	30' x 1/2" Hose reel 506 122	Dispense handle 186 300	Cage	WWF/AF
3228RDC			Dual containment	WWF/AF
3228	10' Hose 824 2		Cage	WWF/AF
3228DC			Dual containment	WWF/AF

330 GAL PACKAGES

Dimensions

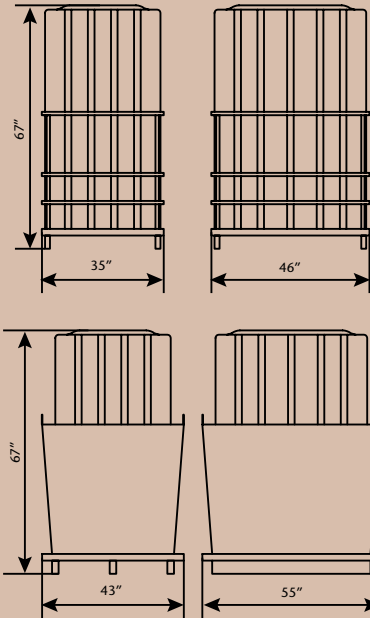

Tanks contain three 2" bung openings



PART No.	DISPENSE HOSE	DISPENSE HANDLE	TANK TYPE	FLUIDS	
BARE TANKS					
3333	330 gal bulk tank - tank and cage only		Cage	ALL	
3333DC	330 gal bulk tank - tank and dc only		Dual containment	ALL	
PACKAGES FOR OIL WITH PM2 3:1 PUMP					
3334	10' Hose 847	Metered handle 365 536	Cage	OILS	
3334DC			Dual containment	OILS	
3332	30' x 1/2" Hose reel 506 202		Cage	OILS	
3332DC			Dual containment	OILS	
3336	50' x 1/2" Hose reel 506 222	Preset metered handle 365 817	Cage	OILS	
3336DC			Dual containment	OILS	
3336P			Cage	OILS	
3336DCP			Dual containment	OILS	
PACKAGES FOR OIL WITH PM4 5:1 PUMP					
3338	50' x 1/2" Hose reel 506 222		Metered handle 365 536	Cage	OILS
3338DC		Dual containment		OILS	
3338P		Preset metered handle 365 817	Cage	OILS	
3338DCP			Dual containment	OILS	
PACKAGES FOR DEF WITH AIR-POWERED DIAPHRAGM PUMP 552 164A					
550 004 330	30' x 1/2" hose reel 506 702	Automatic nozzle 688 303	Cage	DEF	
PACKAGES FOR DEF WITH 110 V AC ELECTRIC DIAPHRAGM PUMP 560 215					
555 112 330	30' x 1/2" hose reel 506 702	Automatic nozzle 688 303	Cage	DEF	
PACKAGES FOR WATER BASED FLUIDS WITH AIR-POWERED DIAPHRAGM PUMP 552 164					
3328R	30' x 1/2" hose reel 506 122	Dispense handle 186 300	Cage	WWF/AF	
3328RDC			Dual containment	WWF/AF	
3328	10' Hose 824 2		Cage	WWF/AF	
3328DC			Dual containment	WWF/AF	

TANK-LESS PUMP AND REEL PACKAGES

Tank-less packages include a PM2 3:1, PM4 5:1 or PM35 5:1 stub pump with bung adaptor, air quick coupler, air nipple and air filter and regulator combo with a hose and metered oil gun listed for each package model.

Packages does not include extension tube for the stub pump

ORDERING INFORMATION

INCLUDED PUMP	HOSE REEL	BUSHING ⁽¹⁾	ADAPTOR ⁽²⁾	HOSE END METER	FILTER + REGULATOR	AIR COUPLER	AIR NIPPLE	PACKAGE PART No.
PM2 3:1 STUB PUMP WITH BUNG ADAPTOR, PN 353 120	506 202	2065	2051	365 537	955	930F04	933M04	900 340
	1426	2065	2051	365 537	955	930F04	933M04	900 341
	1426	2065	2051	365 806	955	930F04	933M04	900 342
PM4 5:1 STUB PUMP WITH BUNG ADAPTOR, PN 347 120	1426	2065	2052	365 537	957	930F06	933M06	900 540
	1426	2065	2052	365 806	957	930F06	933M06	900 541
	504 250	2065	2052	365 537	957	930F06	933M06	900 542
	504 250	2065	2052	365 806	957	930F06	933M06	900 543
PM35 5:1 STUB PUMP WITH BUNG ADAPTOR, PN 535 531	504 250	2065	2052	365 817	957	930F06	933M06	900 544
	1426	2097	2052	365 537	957	930F06	933M06	900 440
	1426	2097	2052	365 806	957	930F06	933M06	900 441
	504 250	2097	2052	365 806	957	930F06	933M06	900 442
504 250	2097	2052	365 817	957	930F06	933M06	900 443	

(1) For pump to hose reel connection
(2) For pump to FR connection

900 340



900 543



900 443

